

MEILENSTEIN
GIPFELSTURM
RUNDKURS
AUTOBAHN
FERNWEG



Owner's manual



INTRODUCTION

Preface	4
Lightweight online	4
Explanation of symbols	4
Your wheel	5
Registration	5

TECHNICAL DATA

Wheels	6
Hubs	7

SAFETY

Intended use	8
In your own interest	8
Fundamental safety precautions	8
... assembly & maintenance	8
... on the road	8
... transport & storage	9

PREPARATORY WORK & ASSEMBLY

Before every ride	10
Lightweight & THM "Scapula F"	11
Fitting the valve extension	11
Installing (adhering) the tyres	12
Installing the cassette	14
Installing the wheels	15
Installing the brake pads	18
Computer magnet	19
Before every ride	20

RIDING & BRAKING

On the road	22
How to brake correctly	23

MAINTENANCE

Important maintenance information	24
Before every ride	26
Regular maintenance	26
Cleaning	26
Hubs	28
Rotor replacement	29

RULES

Liability	34
Service	35
Crashreplacement	35
Fair deal promise	35

Preface

Congratulations and thank you – you have selected the best wheels in the world.

Handarbeit für Beinarbeit – made in Germany.

This manual is an integral component of your Lightweight product and it provides you with important information regarding the safe operation of your Lightweight wheels.

The safety of our customers is very important to us. Please read this manual carefully before installing your wheels or riding on them for the first time.

▲ WARNING Non-observance of the information contained in this manual could result in a fatal or serious accident.

Our information is there for a reason – our interest in your personal safety!

Read and observe all assembly, maintenance and usage instructions and please remember that even the best product can fail if it is improperly treated.

This applies for components from other manufacturers whose products are used on your bicycle (tyres, quick release skewers, brakes etc.).

Read and observe all user instructions.

Keep this manual for other users of your wheels. Make sure that all users read, understand and observe this manual.

If you ever sell or give away your wheels, this manual should be transferred to the new owner.

We hope you get a lot of enjoyment from your Lightweight wheels.

Your Lightweight Team

Lightweight online

Visit www.lightweight.info for information that you will find interesting.

Accessories, spare parts and clothing in the **FANLAGER**, frequently asked questions in the **FAQs**, interesting facts in **NEWS & PRESS** and much more.

We look forward to meeting you there!

Explanation of symbols

You will encounter the following symbols and references in this manual:

- ☞ The index finger instructs you to perform a particular action.
- ➔ The arrow indicates the consequences of your action or important prerequisites.
- ① This shows additional information or tips.

OBERMAYER: This reference refers only to the corresponding series or its derivatives.

▲ WARNING The **WARNING** message indicates a hazardous situation which, if not avoided, could result in a fatal or serious injury.

▲ CAUTION The **CAUTION** message indicates a hazardous situation which, if not avoided, could result in minor or moderate injury.

NOTICE The **NOTICE** message warns of a risk of material damage.

- The dot indicates how to avoid a hazardous situation or a risk of material damage.

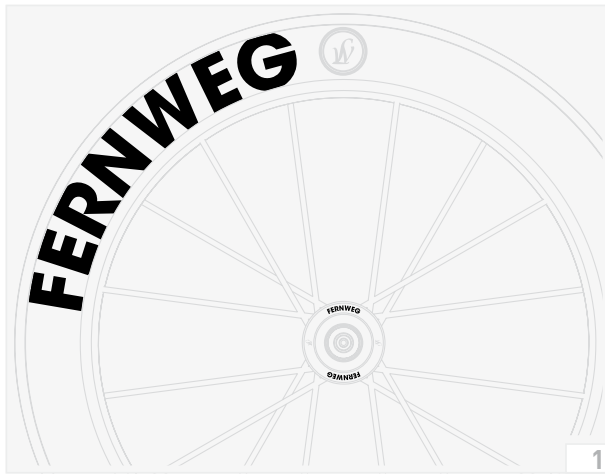

Your wheel

The illustrations in this manual may be different from your Lightweight wheel, but the required steps are the same for all wheel types, unless otherwise specified.

① The model name of your wheel is on the rim flank and the hub cover. (fig. 1)

Registration

Every Lightweight wheel is provided with an integrated chip with a 10-digit code – the chip number. This allows every single wheel to be individually registered.

① Only Lightweight products registered by the original owner or reregistered by subsequent owners enjoy our service provisions!

① To register your Lightweight wheels or change the registration, you can find the required chip numbers in the rim well or on a tab fixed to a spoke of the wheel or your specialist shop has already attached it to the last page of this manual. (fig. 2)

☞ Register or transfer the registration of your Lightweight wheels at www.lightweight.info >>> SERVICE.

→ Our service provisions are available to you.

You will also find information on our extended service offers here.



TECHNICAL DATA

Wheels		Spokes	Rim height/width (mm)	Approved tyre width min.-max.* (mm)	Approved use **	Approved total weight max. (kg/lb)***	Valve min. (mm)	Hub			
SERIES	DERIVATIVE										
MEILENSTEIN	FW	16	47,5/20,0	19-27	Street	100	60	Lightweight			
		20							All-round	120 (265)	DT Swiss® 240s
	RW	20			Street	90		Lightweight			
	OBERMAYER	FW							16	100	DT Swiss® 190s
		RW							20		
	PRO	FW							16	90	Lightweight
		RW			20	100		DT Swiss® 240s			
	GIPFELSTURM	FW			20				27,0/19,5	Street	110
RW		24	DT Swiss® 190s								
RUNDKURS	FW	20			47,5/20,0	Track	120 (265)	60	Lightweight track		
		RW	20								
	DISC	FW	-							-	19,5
		RW	-								
AUTOBAHN	FW	8	79,5/20,0	Street	90		100	Lightweight			
	RW	-							-	19,5	20
FERNWEG	FW	16	79,5/20,0		110		100	Lightweight			
	RW	20							DT Swiss® 190s		

* Select tyres with a width of 22-25 mm and an inflation pressure of 8 bar (116 psi)!

** street = paved or asphalted surface · allround = street and cross-country · track = velodrome

*** Max. permissible total weight = rider + bicycle + luggage

Hubs			Dimension (mm)	Rotor	Threaded sprocket	Fixing	Bearings
LIGHTWEIGHT	TRACK	FW	100	–	–	Quick release	Stainless steel
		FW	100	–	–	M5	
		RW	120 (130 optional)		1.37" × 24 tpi (FG 34,8); 1.29" × 24 tpi (FG 32,8)	M10×1	
DT SWISS® 190s		RW	130	Shimano® 11s* or Campagnolo® C9/C10/C11	–	Quick release	
DT SWISS® 240s		RW					

* Incl. spacer (t=1.9 mm) for 10s cassette.

- ① Technical specifications, dimensions and weights are to be understood with the corresponding allowances and can insignificantly differ from your Lightweight product.
- ① All Lightweight products are the result of manual labour. Deviations in colour and surface finish are characteristic features resulting from this high quality manufacturing procedure.
For more details and information on the manufacture of your Lightweight wheels please consult www.lightweight.info

Intended use

⚠ WARNING

Any use other than that intended can lead to accidents resulting in fatal or serious injury.

Your Lightweight tubular tyres are designed solely:

- for installation on standard race and time trial bikes.
- for the approved application – see **Technical data**, page 6.
- for installation (adhesion) of tubular tyres.

In your own interest

Always remember that riding a bicycle involves potential danger for the rider and other road users, as well as for the bicycle and its components.

Even if protective equipment and safety devices are used, accidents resulting in death or serious injury can still occur.

You should also rely on your common sense and avoid any unreasonable behaviour!

Fundamental safety precautions

... assembly & maintenance

⚠ WARNING

Risk of accident through damaged wheels.

- Do not overestimate your technical ability. All assembly and maintenance work should be performed by a specialist workshop for bicycles. This is the only way to ensure that work is conducted in a professional manner.
- Always maintain all specified min./max. values – see **Technical data**, page 6.
- Only use original Lightweight brake pads. They are available from your specialist shop or directly from CarbonSports.

Risk of accident caused by tyre malfunction.

- Only ever use high quality and undamaged tubular tyres and suitable adhesive.
- Your tubular tyres should only be installed (adhered) by an expert bicycle mechanic.
- Observe the min./max. inflation pressure values specified by the manufacturer.

NOTICE

Never use aggressive solvents (e.g. paint thinner, nitro etc.) as they could damage the surface of your Lightweight components.

- Use only standard paintwork cleaning products and water when cleaning your Lightweight components.
 - Isopropanol, spirits or petrol may be used carefully; however, you should avoid excessive wiping and long exposure times and also any contact with the rim decor.
- ① We recommend our specially developed Lightweight **CLEANER FOR BRAKE TRACK AREAS** for cleaning, available from your specialist shop or directly from CarbonSports – but avoid all contact with the rim decor!

... on the road

⚠ WARNING

Risk of accident through damaged wheels.

- Avoid riding through potholes or over edges and steps.
- Always check your wheels before every ride, after a violent shock and after a blow-out (dents, scratches, cracks, large areas of abrasion etc.). Send us your wheels for inspection before using them again if there is visible damage or if you have any doubts about their condition.
- Never ride with damaged wheels.
- Never continue using your bicycle after a serious crash. If such a case occurs, send your wheels to us for inspection even

if no external damage is visible.

In your own interest you should deal in the same way with all components on your bike that are produced by other manufacturers.

- Do not use your wheels at an ambient temperature below -10°C (14°F) or above 45°C (113°F).

Risk of accident caused by an insufficient braking effect or erratic braking as a result of worn brake track areas.

- Brake judder occurring during riding indicates worn or damaged brake track areas. Stop riding your bicycle immediately if this occurs.

If such a case occurs, send your wheels to us for inspection.

Risk of accident caused by erratic riding or improper equipment.

- Observe the advice on correct braking – see **How to brake correctly**, page 23.
- Pay particular attention when riding in high winds. Front wheels are more sensitive to side winds from a rim height of 30 mm – the higher the rim the greater the sensitivity (e.g. AUTOBAHN, FERNWEG – rim height up to 81 mm). Unwanted steering movements may result.
- Always observe the traffic regulations of the country where you are riding your bicycle.
- When riding your bicycle always wear a high quality cycling helmet (e.g. ANSI certified), that is in excellent condition and close-fitting but not restrictive clothing.
- Only ride your bicycle if you are in good physical condition and your bicycle and all its components are working perfectly.

... transport & storage

⚠ WARNING

Risk of accident through damaged wheels.

- Protect your wheels from lateral pressure. This applies particularly during transport and particularly to disc wheels (RUNDKURS DISC, AUTOBAHN) and also for the FERNWEG series.
- Do not store your wheels at an ambient temperature below -15°C (5°F) or above 55°C (131°F).

NOTICE

AUTOBAHN & FERNWEG: The covers of the Lightweight Aero wheels consist of 1 layer of carbon with reduced wall thickness and they can be easily damaged.

- Do not hang your bicycle on a hook by the Aero front or rear wheel.
- When transporting your bicycle on a car rack, make sure that the straps, hooks etc. cannot damage the covers – use suitable padding where necessary to ensure that any pressure is evenly distributed over a wide area. (fig. 3)

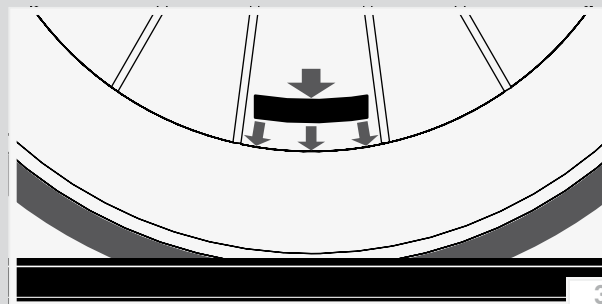



Before every ride

⚠ WARNING Risk of accident through damaged wheels.

- Read and observe all assembly and maintenance instructions, including those specified in the user instructions provided by other manufacturers whose products are used on your bicycle (tyres, quick release skewers, cassettes, brakes etc.).
- Do not overestimate your technical ability. All assembly and maintenance work should be performed by a specialist workshop for bicycles. This is the only way to ensure that work is conducted in a professional manner.
- Check the rims and spokes of your wheels for damage (dents, scratches, abrasion extending over a large area etc.).
- Never ride with damaged wheels.

⚠ WARNING Risk of accident caused by an insufficient braking effect or erratic braking as a result of dirty brake track areas.

- Make sure that the brake track areas on your wheels are free of brake pad residues and soiling.
- Make sure that the brake track areas on your wheels are free of tubular tyre cement.

① We recommend our specially developed Lightweight **CLEANER FOR BRAKE TRACK AREAS** for cleaning, available from your specialist shop or directly from CarbonSports – but avoid all contact with the rim decor!

⚠ WARNING Risk of accident caused by an insufficient braking effect or erratic braking as a result of inappropriate brake pads.

- Install a complete kit of new brake pads on your brakes – see **Installing the brake pads**, page 18.
- Only use original Lightweight brake pads, available from your specialist shop or directly from CarbonSports. **(fig.5)**



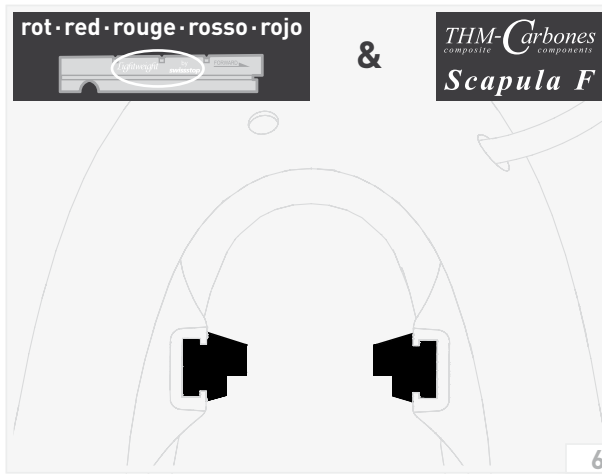

Lightweight & THM "Scapula F"

ⓘ **GIPFELSTURM:** The combination with the THM-Carbones "Scapula F" fork requires the special milled and red-marked Lightweight brake pads, because the integrated Scapula F front-wheel brake does not allow adjustment of the brake pads to the brake track area.

The normal Lightweight brake pad will irreparably damage this Lightweight rim below the brake track area.

⚠ **WARNING** Risk of accident caused by damaged wheels due to unsuitable brake pads.

- Use exclusively the special milled and marked with red Lightweight brake pad, available directly from CarbonSports, with the combination of Lightweight GIPFELSTURM with the THM-Carbones "Scapula F" race bike fork. (fig. 6)

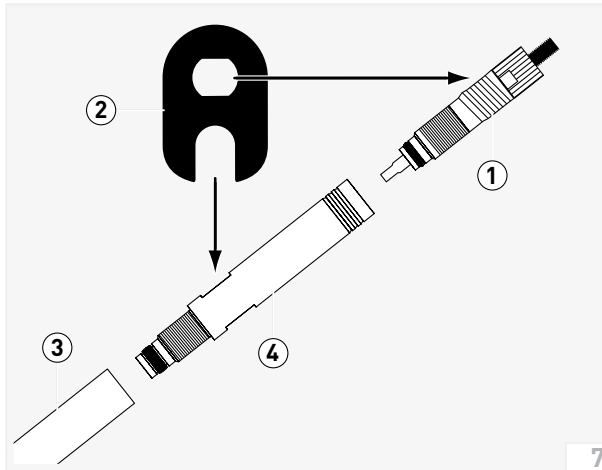

Fitting the valve extension

- ☞ Screw the valve insert (1) using the supplied tool (2) out of the valve shaft, which may be too short (3).
- ☞ Screw the Lightweight valve extension (4) into the valve shaft (3).
- ☞ Screw the valve insert (1) into the valve extension (4). (fig. 7)



Installing (adhering) the tyres

- ☞ Before adhering your tubular tyre, install the valve extension if required, because this will not be possible later – see **Fitting the valve extension**, page 11.
- ☞ Prior to adhesive bonding, fill your tubular tyre with puncture protection sealant.

▲ WARNING Risk of accident due to tyre failure.

- Only ever use high quality and undamaged tubular tyres, such as the Lightweight tubular tyres from Continental®, and suitable adhesive.
- Use puncture protection sealant. We recommend the product from "ZERO FLATS".
- Your tubular tyres should only be installed (adhered) by an expert bicycle mechanic.
- Always maintain all specified min./max. values – see **Technical data**, page 6.
- Follow all the processing instructions provided by the adhesive and tubular tyre manufacturer.
- Observe the min./max. inflation pressure values specified by the manufacturer.

① The lower the inflation pressure or tyre width the higher the risk of a pinch flat. It is always best to use tyres that have a width of 22–24 mm and **8 bar (116 psi)** inflation pressure!

▲ WARNING Risk of accident caused by an insufficient braking effect or erratic braking as a result of dirty brake track areas.

- Make sure that the brake track areas on your wheels are free of tubular tyre cement.

▲ CAUTION Risk of damage to health caused by improper handling of solvents and adhesives.

- Follow all the manufacturer's safety instructions.

NOTICE Only use suitable plastic tyre levers when removing your tyres – do not use metal tyre levers under any circumstances. Avoid excessive levering.

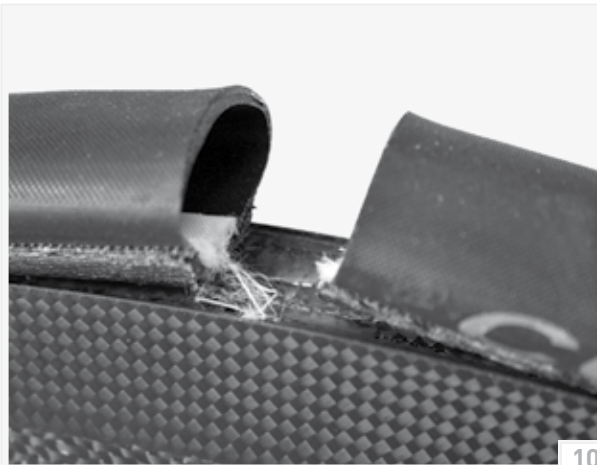

10



11

NOTICE Never use aggressive solvents (e.g. paint thinner, nitro etc.) as they could damage the surface of your Lightweight components.

- Isopropanol, spirits or petrol may be used carefully; however, you should avoid excessive wiping and long exposure times and also any contact with the rim decor.
- ① We recommend our specially developed Lightweight **CLEANER FOR BRAKE TRACK AREAS** for cleaning, available from your specialist shop or directly from CarbonSports – but avoid all contact with the rim decor!
- ☞ Use suitable adhesive for bonding your tubular tyres.
We recommend the tubular tyre cement produced by Continental®. Both available versions (orange for aluminium rims and black for carbon rims) are suitable.
- ☞ Only roughen the rim well of brand new wheels carefully by using fine sandpaper (240 grit or finer).
- ☞ Clean the rim well thoroughly.
- ☞ Adhere the tubular tyre in accordance with the instructions provided by the adhesive and tubular tyre manufacturer.
- ① You can watch our installation video at www.lightweight.info >>> **SERVICE**.

NOTICE **DISC:** Irreparable damage to the cover of the disc wheel by improper installation of the tubular tyre.

- Never pull the tubular tyre sideways from the rim well.
- ☞ When installing the tubular tyre, leave an area of about 20 mm opposite the valve hole when applying the tubular tyre cement. (fig. 9)
- ☞ **Carefully** cut through the defective or punctured tubular tyre at the centre of the clear area with a sharp knife.
Do not damage the carbon fibres! (fig. 10)
- ☞ **Carefully** pull off the tubular tyre vertically to the rim well. (fig. 11)



12

Installing the cassette

① The rotor on the Lightweight rear wheels can be replaced in the event of a system change (e.g. from Shimano®/SRAM® to Campagnolo® – or vice versa) – see **Rotor replacement**, page 29.

NOTICE Fit the Lightweight spoke protector to reduce the risk of damage to the rear wheel caused by the chain slipping off. (fig. 12)

① The Lightweight spoke protector is available from your specialist shop or directly from CarbonSports.

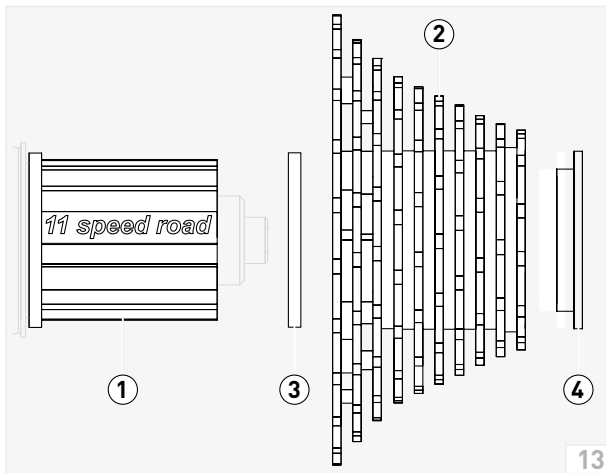

13

☞ Ensure that your cassette complies with the rotor type of your rear wheel.

① A Shimano 11-speed road rotor (1) can have a Shimano®/SRAM® 10s cassette (2) installed.

Use the included spacer (3) (t=1.9 mm) only in this case.

(fig. 13)

① A C9, C10 or C11 cassette by Campagnolo® can be installed on the Campagnolo® rotor without a spacer.

☞ Follow the instructions of the manufacturer when installing your cassette.

☞ Tighten the lock ring (4) of your cassette to the tightening torque specified by the manufacturer.

To do this, use a torque wrench designed for the specified tightening torque.

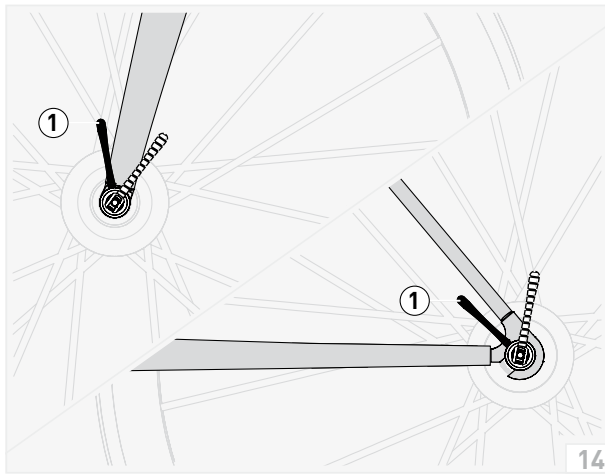

Installing the wheels

⚠ WARNING Risk of accident through malfunction of the quick release skewer caused by improper assembly.

- Observe all the instructions and information provided by the manufacturer of your quick release skewer.
- ☞ Make sure that your quick release skewer complies with the dimensions specified – see **Technical data**, page 6.
- ☞ Follow the instructions provided by the manufacturer when installing your quick release skewer.
- ☞ Mount your wheels in your race bike's dropouts.
- ☞ Make sure that, after closing, the levers (1) are in a position that prevents accidental opening while riding – e.g. due to trapping. (fig. 14)

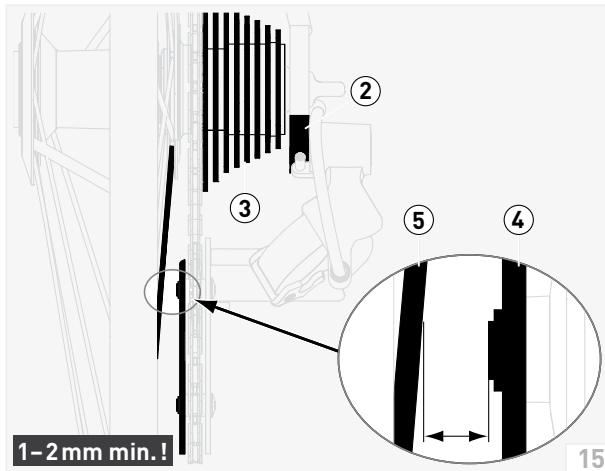

⚠ CAUTION Risk of accident by blockage of the rear wheel caused by incorrectly positioned rear derailer.

- Make sure that the derailer hanger (2) of your bicycle frame is exactly parallel to the sprocket set (3).
- Make sure that the chain cannot move beyond the large sprocket and that there is a minimum clearance of 1–2 mm between the pulley cage (4) and the rear wheel spokes (5).
- ☞ Shift the chain to the small chain ring.
- ☞ Carefully shift the chain to the large sprocket.
- ☞ Re-adjust the inner limit stop of your rear derailer if the pulley cage (4) is closer than 1–2 mm to the rear wheel spokes (5). (fig. 15)

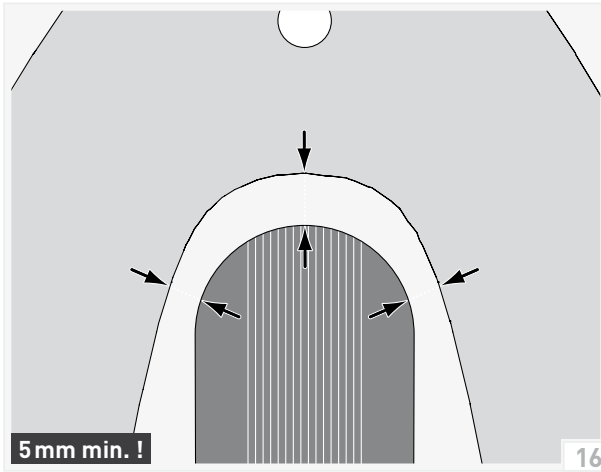

▲ WARNING Risk of accident due to wheels locking as a result of insufficient clearance.

- Make sure that the clearance between the tyres and rear stays/seat tube and/or fork blades/fork head is **at least 5 mm.** (fig. 16)
Use narrower tyres if necessary.

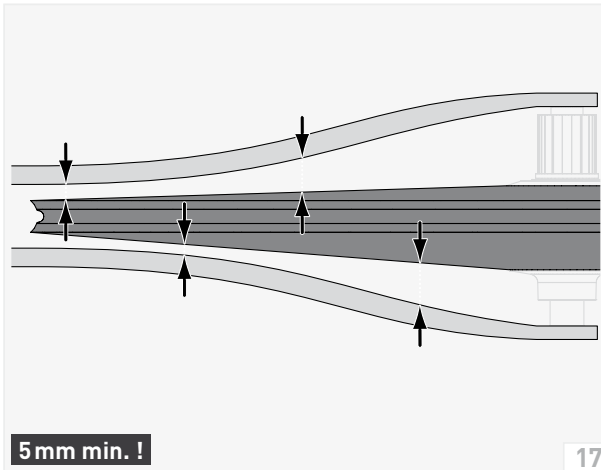

NOTICE DISC: Damage to the wheel and frame due to friction on the seat or chain stay.

- Make sure there is a **minimum clearance of 5 mm** between the Lightweight DISC and all rear stays. (fig. 17)
Otherwise we recommend not installing the Lightweight DISC in that frame!

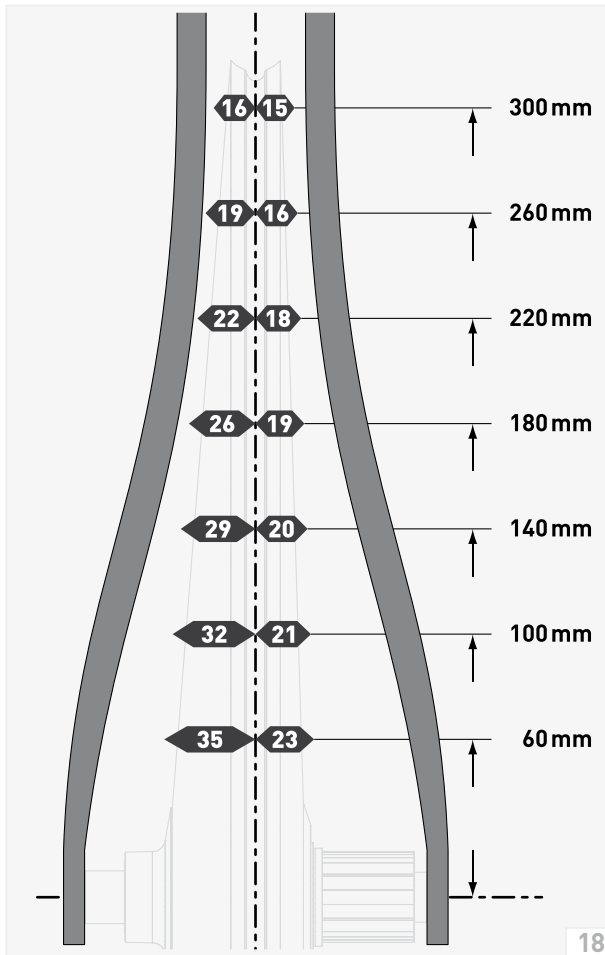

① **DISC:** The number of narrow rear frames on aerodynamic race bike frames is increasing, which can cause problems, particularly with an asymmetric design. If you are planning to purchase a new race bike frame with which you wish to use the Lightweight **DISC**, check with the frame manufacturer to make sure that your proposed frame is suitable.

- ☞ Check all measuring points (60 mm ... 300 mm) to make sure that there are the required clearances between the rear stays –
Be particularly careful with asymmetrical rear triangles!
- ➔ The specified dimensions include the required clearance between Lightweight **DISC** and rear stays (5 mm).
(fig. 18)

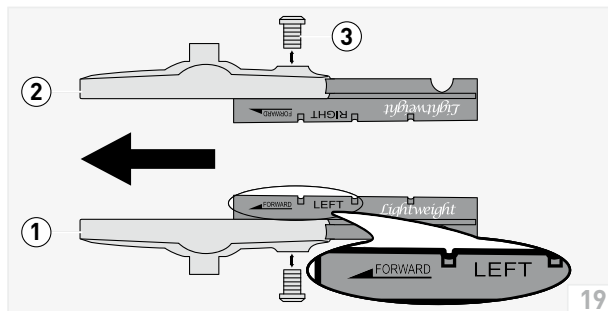

Installing the brake pads

⚠ WARNING Risk of accident caused by an insufficient braking effect or erratic braking as a result of inappropriate brake pads.

- Only use original Lightweight brake pads. They are available from your specialist shop or directly from CarbonSports.

⚠ WARNING Risk of accident caused by insufficient braking effect caused by new brake pads.

- New brake pads and brake track areas (6) only reach their full braking effect during the running-in period. (fig. 20/21)

Select your speed to reflect this during your first rides.

NOTICE Replacing Lightweight brake pads with brake pads from another manufacturer could cause serious damage to the brake track areas of your Lightweight wheels.

☞ Make sure that all brake pads are correctly installed as follows:

- The arrow (FORWARD) should be facing the direction of travel (to the front).
- The brake pad with LEFT labelling must be installed in the left-hand brake shoe (1), RIGHT in the right-hand brake shoe (2).

☞ Slide the Lightweight brake pads into their brake shoes.

☞ Shimano®/SRAM®: Tighten the securing bolts (3) with a tightening torque of 1.0–1.5 N·m (9–13 lbf·in). (fig. 19)

☞ Carefully adjust the brake shoes.

☞ Tighten the bolts (4) on the brake shoes (5) with the correct tightening torque. Shimano®/SRAM®: 5–7 N·m (44–62 lbf·in)
Campagnolo®: 8 N·m (71 lbf·in)
(fig. 20/21)

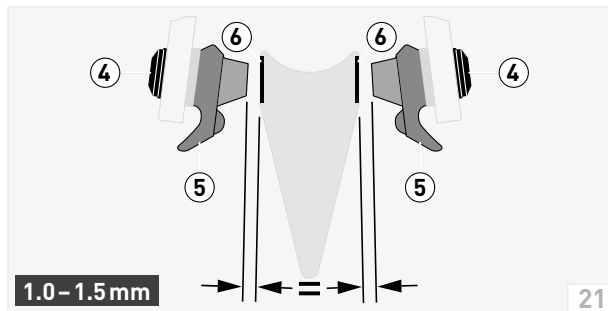
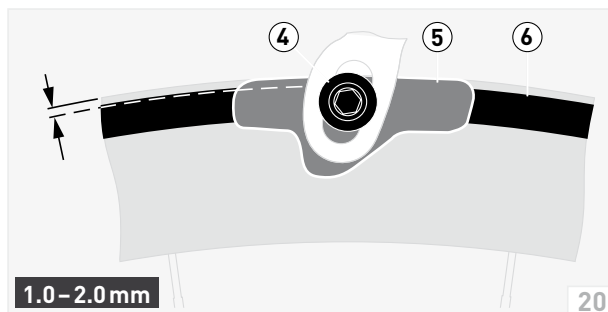

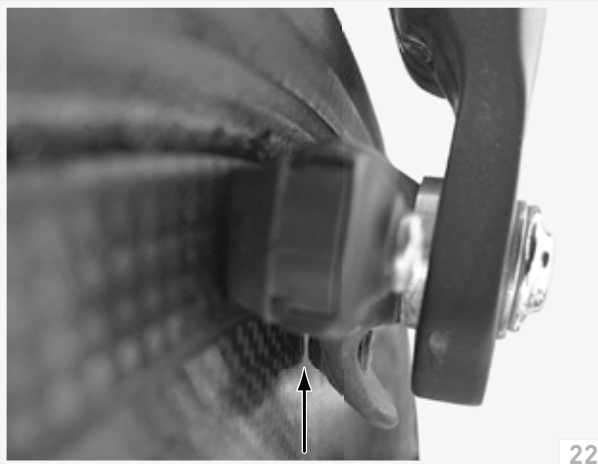

NOTICE **AUTOBAHN & FERNWEG:** Brake shoes on race bikes are generally fitted with a "wing". It is used as a guide during installation of the wheel. (fig. 22) Because of the aerodynamic rim profile of Lightweight Aero wheels, the wing may come into contact with the surface of the rims when the brake pad is 50% worn.

The covers of the Lightweight Aero wheels consist of 1 layer of carbon with reduced wall thickness and they can be easily damaged.

- Use brake shoes without wings.
- Check the distance between wing and rim surface at regular intervals with the brake lever set.
- Replace the brake pads regularly – at the latest when the distance between wing and surface of the rim is less than 1 mm with the brake lever set.

Computer magnet

① All Lightweight front and rear wheels have an integrated computer magnet. The magnet symbol identifies the location of the incorporated magnet.

GIPFELSTURM: The computer magnets – without magnet symbol – are attached to a spoke. (fig. 23)

- ☞ Fit the wheel to the front fork or the rear triangle of your race bike.
- ☞ Install the sensor of your computer.
- ☞ Align the computer sensor with the magnet symbol.

① If correct alignment of the front wheel sensor and Lightweight magnet is impossible due to the fork design, ask your specialist shop for an appropriate spoke magnet.

⚠ WARNING Risk of accident due to spoke breakage.

- Never use spoke magnets fitted by clamping screws – the clamping screw will cause severe damage to the fibres of the carbon spokes.

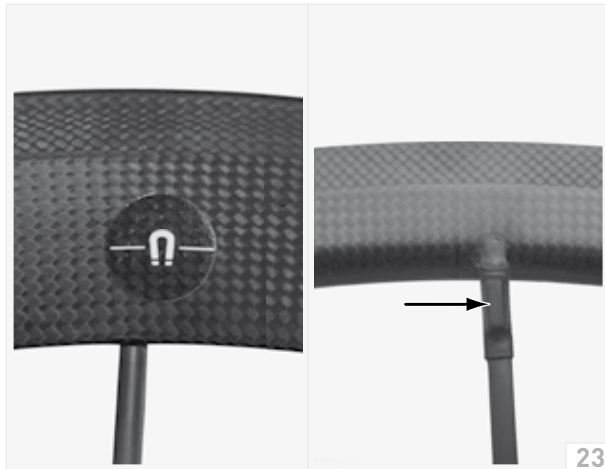

Before every ride

⚠ WARNING Risk of accident caused by material damage or improper assembly.

- Never use damaged wheels or defective tyres.
- Check your quick release skewer and wheels for tight and correct seat.
- Never exceed the max. permissible total weight – see **Technical data**, page 6.
- Observe the min./max. inflation pressure values specified by the manufacturer.

⚠ WARNING Risk of accident caused by an insufficient braking effect or erratic braking as a result of dirty brake track areas.

- Make sure that the brake track areas on your wheels are free of tubular tyre cement, brake pad residues and soiling.
- Make sure that the brake track areas of your wheels are free from lubricants (grease, oil, silicone, Teflon, wax or other such substances).
- Make sure that your cycle chain is only lightly oiled – excess chain oil can work its way onto the brake track area while riding.
- ☞ Check the rims and spokes of your wheels for damage (dents, scratches, abrasion extending over a large area etc.).
- ☞ Check the brake track area on your wheels for foreign bodies – remove any such objects.
- ☞ Check the brake pads for damage (cracks, breakage etc.) and foreign objects (stones, shards of glass etc.).
Replace defective brake pads with new ones and/or remove the foreign objects before riding your bicycle.

- ☞ Check tyres for damaged areas (cracks, abrasion dents etc.).
- ☞ Check tyres for correct air pressure.
- ① The lower the inflation pressure or tyre width, the higher the risk of pinch flat. It's always best to use tyres that are between 22 and 24mm wide with an **8 bar (116 psi)** inflation pressure.
- ☞ Make sure your repair kit (at least 1 tubular tyre, tyre levers, pump) is suitable, complete and intact.

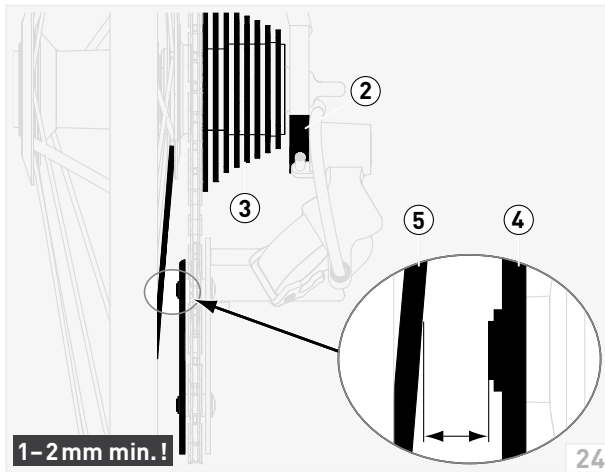

- ☞ Check the gear mechanism for correct adjustment – pay particular attention to the limit stops – see **Installing the wheels**, page 15.
 - ① Please note that if your bicycle falls it can easily cause the derailleur hanger of the frame to be bent inwards. In this case the chain is liable to move beyond the large sprocket and into the area of the rear wheel spokes!
- ▲ CAUTION** Risk of accident by blockage of the rear wheel caused by incorrectly positioned rear derailleur.
- Make sure that the derailleur hanger (2) of your bicycle frame is exactly parallel to the sprocket set (3).
 - Make sure that the chain cannot move beyond the large sprocket and that there is a minimum clearance of 1–2mm between the pulley cage (4) and the rear wheel spokes (5).
- (fig. 24)

On the road

⚠ WARNING Risk of accident through damaged rims.

- Stop as quickly as possible when a blow-out occurs. Never continue riding with a flat tyre.
- Always check your wheels for damage after a violent shock and after a blow-out.
- Never ride with damaged wheels.
- Send us your wheels for inspection before use if damage is visible or if you are worried about your wheels not being in perfect condition.

⚠ WARNING Risk of accident caused by an insufficient braking effect or erratic braking as a result of worn brake track areas.

- Brake judder occurring during riding indicates worn or damaged brake track areas. Stop riding your bicycle immediately if this occurs.
If such a case occurs, send your wheels to us for inspection.

⚠ WARNING Risk of accident through hidden damage caused by a serious crash.

- Never continue using your bicycle after a serious crash.
If such a case occurs, send your wheels to us for inspection even if no external damage is visible.
In your own interest you should deal in the same way with all components on your bicycle that are produced by other manufacturers.

How to brake correctly

Braking with carbon rims is quite different from braking with aluminium rims.

- ☞ It is therefore essential to become familiar with the different braking behaviour and an especially cautious and circumspect riding method is recommended during the initial period!
- ☞ Do not keep the brake pads in constant contact with the rims. This can quickly cause severe heat build up on the brake track areas and cause delamination of the carbon fibres. After this happens, the braking effect is very hard to control and the wheel is permanently damaged.
- ☞ Operate the brakes at intervals (intermittent braking).
 - ➔ **The shorter and harder the braking intervals the better!**
 - ➔ **The longer the brake is released between braking intervals the better!**
- ☞ Please note that new brake pads and brake track areas only reach their full braking effect during the running-in period. Select your speed to reflect this during your first rides!

Braking on a long descent:

▲ WARNING Risk of accident through a reduced braking effect and material damage due to overheating of the brake track area.

- Do not keep the brake pads in constant contact with the rims.
- Operate the brakes at intervals (intermittent braking).
- Adopt a circumspect riding method.

① During long, fast downhill stretches where you need to brake frequently, regular short (1 second) releasing of the brake will considerably extend the lifetime of the brake track areas. Lightweight wheels dissipate heat very quickly – approx. 50 °C (122 °F) per revolution of the wheel!

If you need to apply the brakes for longer periods to ride safely, use the front and rear wheel brakes alternately.

▲ CAUTION Risk of burning on hot brake track areas.

- Allow the brake track area to cool before touching it.
- ☞ You should check the brake track area for thermal deformation especially after a long descent and at high ambient temperature.
- ☞ Never ride with damaged wheels.

Braking in wet conditions:

▲ WARNING Risk of accident through a reduced braking effect and incalculable braking behaviour due to water film on the brake track area.

- Adopt a circumspect riding method.
- Keep the brake pads in slight contact with the rims before braking.
 - ➔ This will eliminate the water film on the brake track area.
 - ➔ Braking effect and behaviour are considerably improved.

Important maintenance information

⚠ WARNING

If not properly performed, assembly and maintenance work can cause accidents resulting in serious or fatal injury.

- Do not overestimate your technical ability. All assembly and maintenance work should be performed by a specialist workshop for bicycles. This is the only way to ensure that work is conducted in a professional manner.

Risk of accident through damaged wheels.

- Read and observe all assembly, maintenance and usage instructions and please remember that even the best product can fail if it is improperly treated.

This applies for components from other manufacturers whose products are used on your bicycle (tyres, quick release skewers, brakes etc.).

Read and observe all user instructions.

- Always maintain all specified min./max. values – see **Technical data**, page 6.
- When conducting assembly steps that require a specific tightening torque, always use an appropriate torque wrench that is designed for the tightening torque specified.
- Only use original Lightweight brake pads, They are available from your specialist shop or directly from CarbonSports.

NOTICE

Never use a pressure washer or steam cleaner to clean your bicycle, as the seals of your bicycle components are unable to withstand the pressure. This results in corrosion and material damage.

Never use aggressive solvents (e.g. paint thinner, nitro etc.) as they could damage the surface of your Lightweight components.

- Use only standard paintwork cleaning products and water when cleaning your Lightweight components.
- Isopropanol, spirits or petrol may be used carefully; however, you should avoid excessive wiping and long exposure times and also any contact with the rim decor.

① We recommend our specially developed Lightweight **CLEANER FOR BRAKE TRACK AREAS** for cleaning, available from your specialist shop or directly from CarbonSports – but avoid all contact with the rim decor!

Furthermore, improperly performed assembly and maintenance work could also result in a loss or your rights with regard to product liability and service!

Always ensure your bicycle is maintained in a flawless condition. Care and maintenance will prolong the service life of your bicycle and its components and improve your personal safety!

If you suspect that your bicycle is defective or is not functioning properly, stop using it and contact a specialist workshop for bicycles!

Disposal

If defective or no longer in use, you can dispose of your wheels with your non-recyclable waste or domestic refuse or ask a local waste disposal company for other ways of disposal (e.g. recycling).

You can also send your wheels to us. They will then be disposed of in a way that is harmless to the environment – see **Crashreplacement**, page 35.

Before every ride

– see **Before every ride**, page 20.

Regular maintenance

Frequency of maintenance work on your bicycle depends on how often and in which weather conditions you are using it. The following maintenance measures should be conducted more frequently if the bicycle is used in extreme conditions (rain, dirt, long distances etc.).

Regular care and maintenance ensures that your bicycle is always clean and well protected by lubricants and preservatives. Ask your specialist shop about appropriate lubricants and cleaning agents as well as information relating to their correct application.

Cleaning

⚠ WARNING Risk of accident caused by an insufficient braking effect or erratic braking as a result of a soiled brake track area.

- Make sure that the brake track areas on your wheels are free of brake pad residues and soiling.
- After conducting any cleaning, maintenance or repair work make sure the brake track areas of your wheels are free from lubricants (grease, oil, silicone, Teflon, wax etc.).
- Make sure that your cycle chain is only lightly oiled – excess chain oil can work its way onto the brake track area while riding.

① Brake pad residues and lubricants can severely impair the effectiveness of your brakes and lead to unpleasant judder during braking.

NOTICE Brake judder can quickly cause severe heat build up on the brake track areas and even delamination of the carbon fibres. After this happens, the braking effect is very hard to control and the wheel is permanently damaged.

NOTICE Soiling and sand act like a file during braking – this destroys the brake track area.

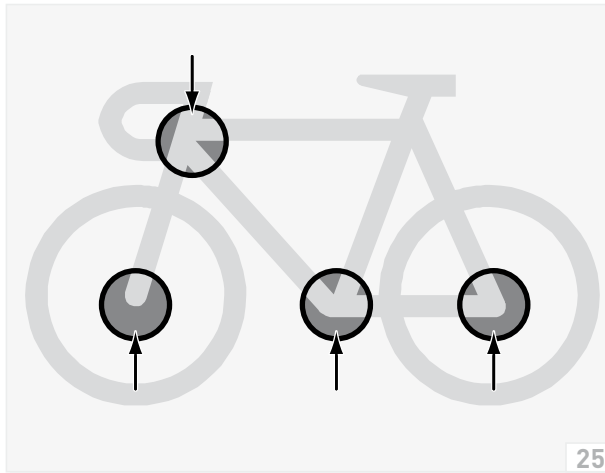

NOTICE Never use a pressure washer or steam cleaner to clean your bicycle, as the seals of your bicycle components are unable to withstand the pressure. This results in corrosion and material damage.

Even if you use a hose, be careful – never aim the hose directly at the bearing components. (fig. 25)

- ☞ Clean your wheels and brake pads at regular intervals – and always after riding in the rain – with water and a non-aggressive, environmentally-friendly cleansing agent.
- ☞ Clean the brake pad residues from the brake track areas of your wheels at regular intervals with Lightweight **CLEANER FOR BRAKE TRACK AREAS**.
- ☞ When cleaning your wheels check rims and spokes for damage (dents, scratches, cracks, abrasion extending over a large area, worn areas etc.) and foreign objects (stones, glass shards etc.) which may have penetrated the brake track areas – remove any foreign objects.
- ☞ Check tyres for damaged areas (cracks, abrasion dents etc.).
- ☞ Periodically preserve the surface of your wheels using a high quality protecting wax or similar.
Never apply wax to the brake track areas!
- ☞ Periodically clean all drive elements of your bicycle (sprockets, chain rings, chain, rear derailleurs, front derailleurs).
- ☞ Lightly lubricate the chain on your bicycle at regular intervals.
- ☞ Periodically check derailleur and brake cables for smoothness of operation.
- ☞ Periodically check all bolts to ensure that they are firmly seated; when doing so observe the respective tightening torques.

Hubs

All hubs in our range of Lightweight wheels are fitted with high quality bearings that require no maintenance. However, their smooth-running attributes can be reduced over time due to wear or they can exhibit increased bearing play.

In this case, please return the affected wheel to us.

- ① Work on the Lightweight front wheel hub should be conducted by us!
Work on the Lightweight rear wheel hub can also be conducted by a DT Swiss Service Centre or a specialist workshop for bicycles.
- ☞ Always keep the hubs on your Lightweight wheels clean.
- ☞ Periodically preserve the surface of the wheel hubs using a high quality protecting wax or similar.

▲ WARNING If not correctly performed, assembly and maintenance work can cause accidents resulting in serious or fatal injury.

- Do not overestimate your technical ability – assembly and maintenance of Lightweight rear wheel hubs should be conducted by a DT Swiss Service Centre or a specialist workshop for bicycles. This is the only way to ensure that work is conducted in a professional manner.
Furthermore, improperly performed assembly and maintenance work could also result in the loss of your rights with regard to product liability and warranty!

For more information please visit www.dtswiss.com

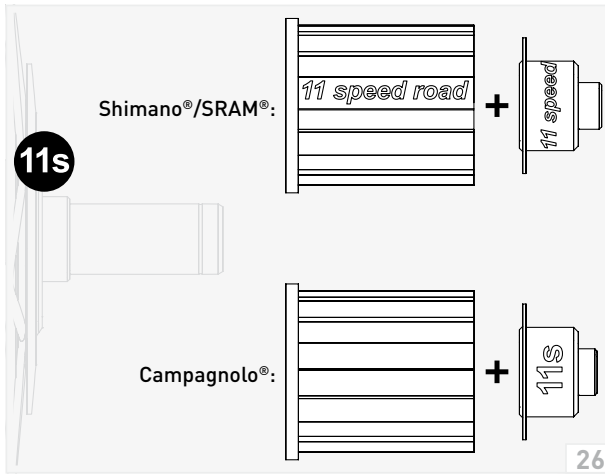

Rotor replacement

⚠ WARNING Risk of accident due to rotor failure.

- Never use a rotor that exhibits cracks or other evidence of serious damage (dents and burrs caused by the cassette have no influence on the function of the rotor and can be ignored).
- Only replace damaged components with original DT Swiss parts.
- Only use original DT Swiss special freewheel grease to lubricate the components. It is available from your specialist shop or directly from CarbonSports.

NOTICE Changing the dimension and non-centring of the rear wheel.

- Shimano®/SRAM®: only use the "Shimano® – 11 speed road" rotor and the correspondingly labelled end stop for a 11s rear wheel.
- Campagnolo®: only use the "Campagnolo®" rotor and the correspondingly labelled rear wheel adapter for a 11s rear wheel. (fig. 26)

- ☞ Release the lock ring (1) of the cassette (2) using an appropriate tool.
- ☞ Remove the cassette from the rotor (3). (fig. 27)

ⓘ Carefully loosen the cassette counterclockwise with a plastic hammer if it is difficult to remove from the rotor.

- ☞ Clean the rotor.
- ☞ Check the rotor for cracks.
- ☞ Inspect the rotor grooves for notches and burrs and, if necessary, eliminate them using a suitable smooth file.

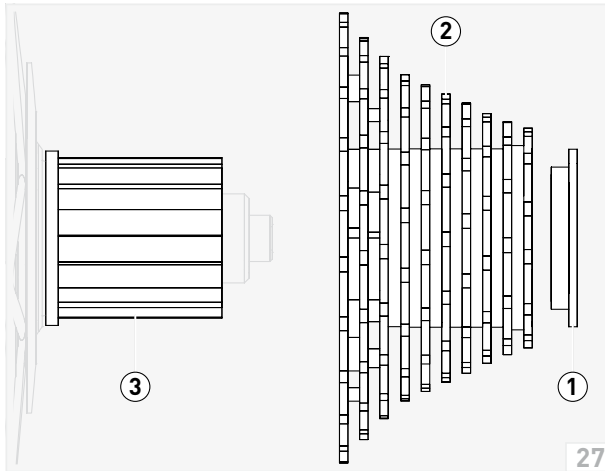

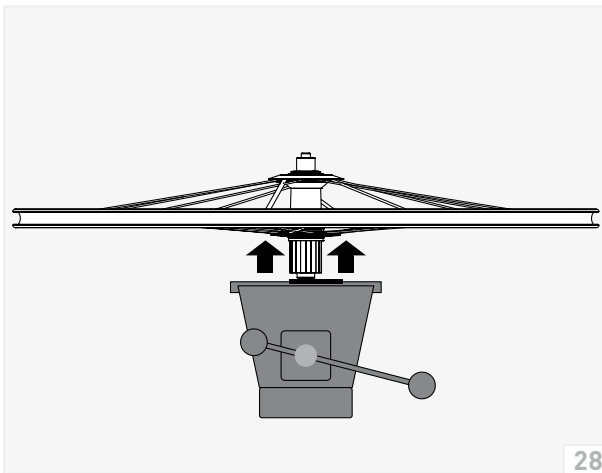

28

- ☞ Clamp the rear wheel adapter of the rotor side in a vice using an appropriate axle retainer.

NOTICE Risk of material damage.

- Do not hold the rear wheel by the rim when removing it.
 - When removing the wheel grasp it from below with both hands to the left and right-hand side of the rotor.
 - Apply an equal pressure to the top at either side.
 - Have the rotor removed by a specialist workshop for bicycles if it is not possible to remove the hub with moderate force.
- ☞ Remove the hub from the rear wheel adapter.
(fig. 28)

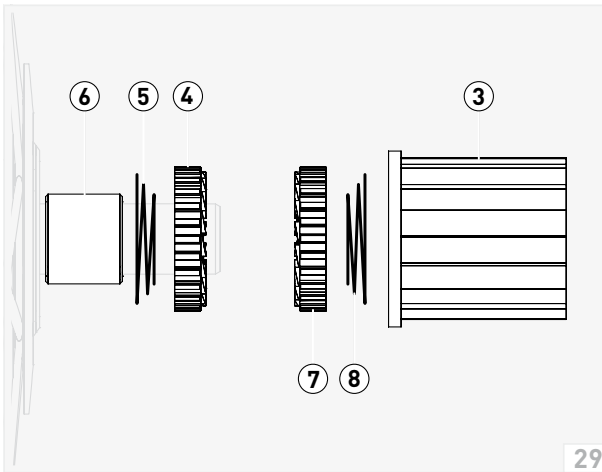

29

- ☞ Remove the rotor (3), toothed lock washer (4), spring (5) and spacer (6) from the axle.
- ☞ Remove the toothed lock washer (7) and spring (8) from the rotor.
(fig. 29)
- ☞ Use a dry cloth or brush to thoroughly clean all components of old grease (including the toothed portions of the rotor and hub).
- ☞ Check all components for damage.

- ☞ Apply a light coat of grease to the inner teeth of the hub and rotor.
(fig. 30)

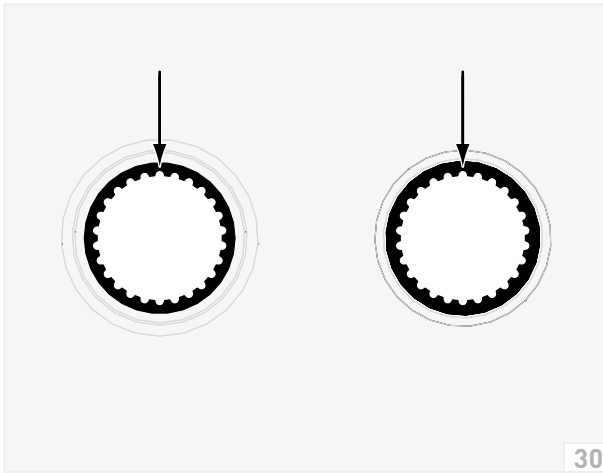

- ☞ Push the spacer **(6)** and spring **(5)** up to the mechanical stop on the axle bearings.
 - The spring side with the larger diameter must lie flush against the bearing!
(fig. 31)

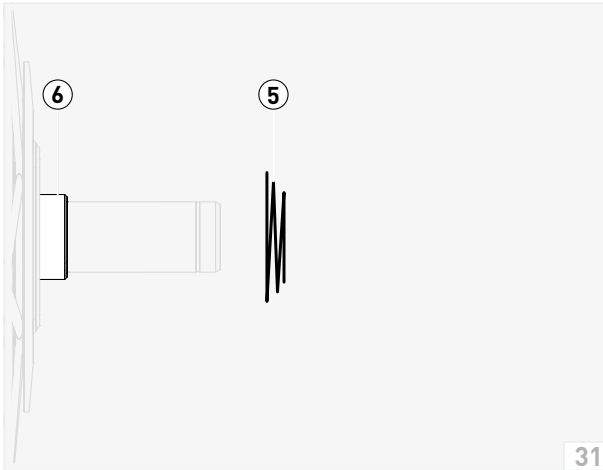

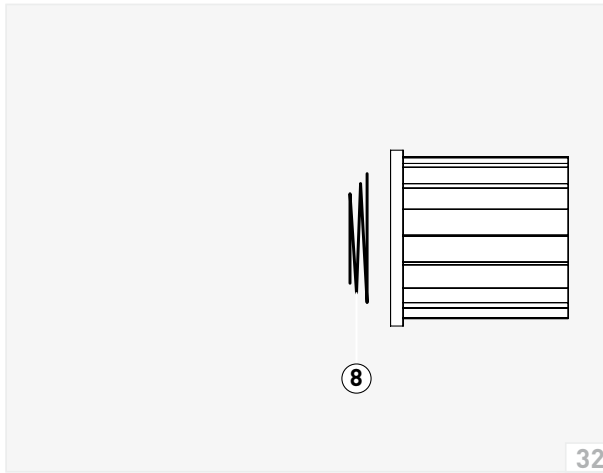

- ☞ Check the bearings of the rotor for smooth and free operation. Have any defective bearings replaced by a specialist workshop.
 - ☞ Insert the spring (8) into the rotor.
 - ➔ The spring side with the larger diameter must lie against the shim of the rotor!
- (fig. 32)

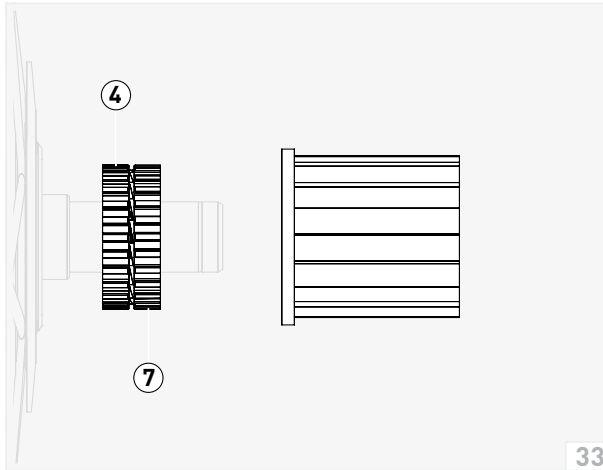

- ☞ Lightly lubricate the toothed lock washers (4) (7).
 - ☞ Place the toothed lock washers – with the toothed portions against each other – onto the axle.
 - ☞ Slide the rotor over the axle.
- Be careful when installing the rotor. Avoid tilting the components!
- (fig. 33)

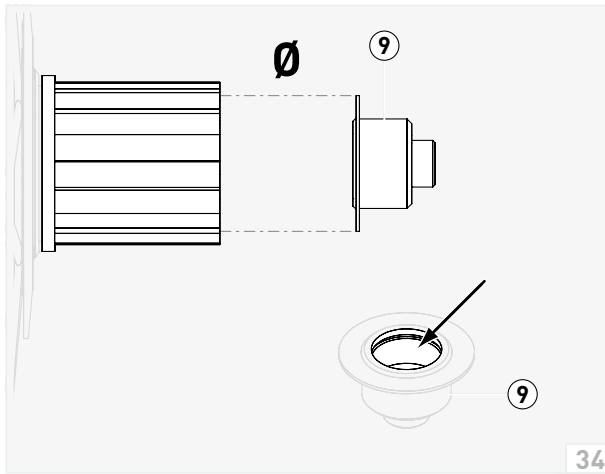

☞ Lightly lubricate the right rear wheel adapter (9) – particularly inside.

NOTICE Loss of function – rotor jams.

- Campagnolo® and Shimano® rotors have different rear wheel adapters and should not be interchanged.
- Make sure the outer diameter (Ø) of the right rear wheel adapter accurately matches the inner diameter of the rotor used.

(fig. 34)

☞ Insert the rear wheel adapter onto the axle and press it by hand until it noticeably locks in place.

➔ This completes installation of the rotor.

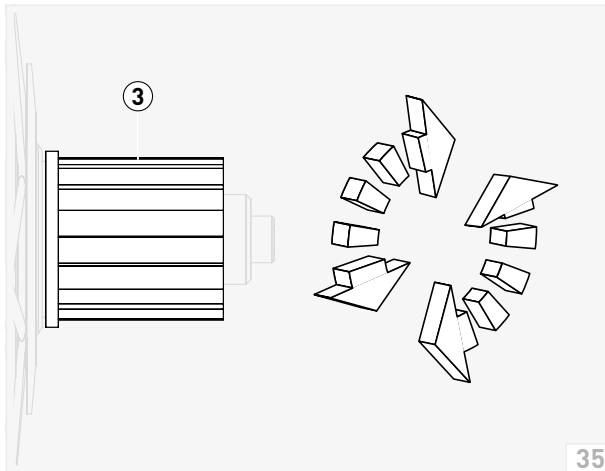

① Check the function of the freewheel mechanism by turning the rotor (3) jerkily and alternately in both directions. (fig. 35)

If the toothed lock washers fail to engage properly, it means that either an excessive amount/unsuitable type of grease has been applied or the freewheel is not correctly installed.

In this case dismantle the rotor and proceed as described above.

☞ Assemble your cassette – see **Installing the cassette**, page 14.

RULES

- ① Please contact our repair department before returning a defective Lightweight product to us!
If products are returned without our previous agreement, the shipping costs incurred will be charged to your account!
- ① When returning a defective Lightweight product please prepay the cost of postage. Any shipment that is not prepaid will be rejected and returned to the sender!
Please send us the defective wheel without any accessories (such as tyres, cassettes, quick release skewers, wheel bags etc.), as we will not assume any liability for possible damage and loss of the aforementioned parts.
We expressly reserve the right to return wheels in an unrepaired state if this requirement is not complied with.
- ① Before returning parts from countries outside Germany, please contact the importer. The importer will handle communications with our repair department on your behalf.
To locate your importer, please go to:
www.lightweight.info >>> CONTACT >>> IMPORTERS

Liability

We provide a legal liability for all Lightweight products which covers material and processing defects. During this period all products accepted as being defective are replaced at no cost to the user.

The liability period starts at the time the Lightweight product was originally purchased.

Liability does not extend to any kind of damage caused by normal wear and tear, accidents, unauthorised modifications, negligence or improper handling and use.

Repair work or any other work conducted on the Lightweight product by unauthorised persons will also void your warranty.

This also applies to any indirect or direct damage resulting from an action as described in the preceding sentence.

- ① Only registered Lightweight products or products whose registration has been transferred to a new owner are entitled to our service rules! – see **Registration**, page 5!

Service

Crashreplacement

In the event of irreparable damage (e.g. caused by an accident) we offer a 40% discount off the German list price if you purchase a new Lightweight product as a replacement in the 1st and 2nd year, and 35% from the 3rd year.

The date of the invoice for the initial purchase defines the discount. Claims for replacement can be submitted directly to CarbonSports GmbH – you can also contact your dealer or the Lightweight importer in your country of residence.

If Crashreplacement is claimed, the irreparable Lightweight product becomes our property.

Fair deal promise

Minor damage to your Lightweight products will be repaired by our workshop free of charge even after expiration of the statutory warranty period, provided that the work required does not exceed 0.5 hrs.

The decision whether or not a repair is to be carried out free of charge rest solely with us – **if you caused the damage yourself, you are not entitled to free repair work!**

If you caused the damage yourself, please send us the product concerned for inspection.

We will then assess the level of work and either perform the repair free of charge or send you a quotation. It is then up to you to decide whether or not to go ahead with the repair work.

Dealer

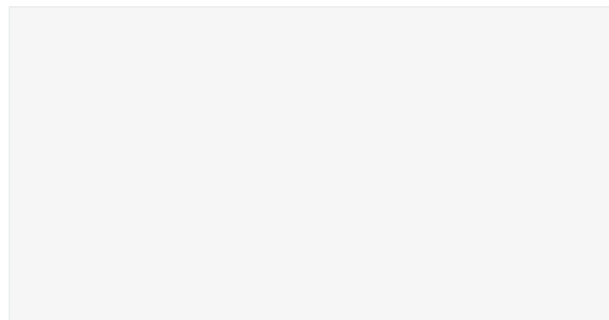

CarbonSports GmbH has a policy to improve products as technical developments continue. We therefore reserve the right to make design alterations in relation to the illustrations and descriptions contained in this owner's manual, without incurring obligation to alter products previously delivered.

Technical specifications, dimensions and weights are to be understood with the usual allowances. Reproduction or translation, in whole or part, is not permitted without the written consent of CarbonSports GmbH.

All rights under the provisions of the Copyright Act are reserved.

Chip number

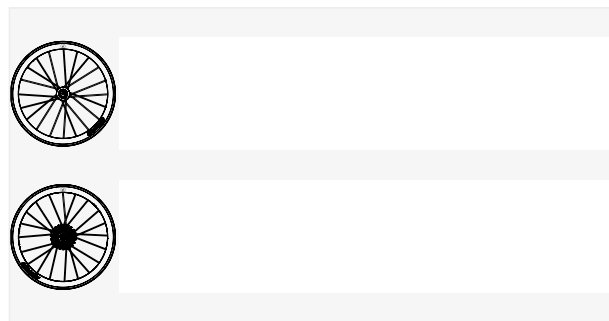

Lightweight

CARBONSPORTS GMBH

Otto-Lilienthal-Straße 15
88046 Friedrichshafen
Deutschland Germany

www.lightweight.info
mail@lightweight.info

Tel: +49 7541 3889 12
Fax: +49 7541 3889 55